

6.4(a)

Ministry of Infrastructure

Ministry of
Transportation

Office of the Minister

Ferguson Block, 3rd Floor
77 Wellesley St. West
Toronto, Ontario
M7A 1Z8
416-327-9200
www.ontario.ca/infrastructure
www.mto.gov.on.ca

Ministère de l'Infrastructure

Ministère des
Transports

Bureau du ministre

Édifice Ferguson, 3^e étage
77, rue Wellesley ouest
Toronto (Ontario)
M7A 1Z8
416-327-9200
www.ontario.ca/infrastructure
www.mto.gov.on.ca



M2013-3749

JUL 05 2013

JUL 10 2013

Mr. Ted Arnott, MPP
Wellington-Halton Hills
Room 420, Main Legislative Building, Queen's Park
Toronto ON M7A 1A8

Dear Mr. Arnott,

Thank you for sharing with me the petition you recently presented in the Legislature regarding Highway 6 through Morriston.

I appreciate the community's desire to move forward with the realignment of Highway 6 between Freelon and Guelph, which would bypass the community of Morriston and provide improved connection to Highway 401 and the Hanlon Expressway (Highway 6). Further to my previous correspondence with you on this issue, Highway 6 between Freelon and Guelph is listed in the Southern Highways Program 2012 to 2016 under "Planning for the Future" for possible future construction. We continue to move the project forward through the completion of a number of pre-construction activities such as protecting the new route from development and acquiring property on a willing buyer-willing seller basis.

Last year my predecessor, the Honourable Bob Chiarelli, met with local municipal representatives. I have been advised that during this meeting Minister Chiarelli asked Mayor Lever to seek out industry advocates to better portray the regional economic benefits of a bypass. I remain committed to taking forward any such information as part of next year's provincial budgeting process when this project is considered for inclusion, along with many other highway expansion priorities, within the five-year Southern Highways Program.

Currently the ministry is monitoring traffic flow in the area and working with the community to promote safety along this stretch of Highway 6. In the short term, the ministry has been working to enhance traffic safety and flow in Morriston by:

- Installing larger speed limit signs in December 2012
- Constructing an extension of the eastbound off-ramp at the Highway 401 and Highway 6 interchange, completed in 2012

.../2

- Adjusting traffic signal timings in the area in fall 2012, and
- Enhancing the existing pedestrian crossing at the Highway 6/Calfass Road intersection, to be completed shortly.

Ministry staff are also working with local residents and business owners towards establishing a Community Safety Zone in Morriston, as well as introducing other traffic calming measures, including streetscaping and a decorative municipal display sign.

Thank you again for your letter.

Sincerely,

A handwritten signature in black ink, consisting of a large, loopy 'G' followed by a horizontal line extending to the right.

Glen Murray
Minister





COUNTY OF WELLINGTON

PLANNING AND DEVELOPMENT DEPARTMENT
GARY A. COUSINS, M.C.I.P., DIRECTOR
T 519.837.2600
T 1.800.663.0750
F 519.823.1694

ADMINISTRATION CENTRE
74 WOOLWICH STREET
GUELPH ON N1H 3T9

July 24, 2013

Mrs. Karen Landry, CAO/Clerk
Township of Puslinch
R.R. 3 (Aberfoyle)
Guelph, Ontario N1H 6H9

Dear Mrs. Landry

Re: Highway 6 Streetscape Strategy
Morriston

We are pleased to provide the Township with the attached Highway 6 Streetscape Strategy for Morriston. This report was created to help mitigate traffic concerns and improve the pedestrian environment. The Morriston strategy includes five new planting areas, fourteen lighting and banner installations and two new entrance signs into the village.

Given the location of Morriston along Provincial Highway 6, all of the proposed streetscape improvements in this report will be within the Highway 6 right-of-way and will require approval of the Ministry of Transportation. MTO is willing to consider the type of improvements proposed but have criteria which must be met in order for approval. This report outlines the necessary MTO requirements as well as other steps which each proposal will have to satisfy in order to be accomplished.

These streetscape improvements were developed through a number of consultation meetings with local business owner Bill Knetsch, MTO representatives and the Township consulting Ecologist as well as numerous site visits. This plan would build upon recent initiatives in Morriston which include larger speed signs, zebra stripping of the main intersection at Highway 6 and Badnoch Street and the proposed community safety zone.

We trust that this strategy is helpful for the Townships implementation of these Streetscape Improvements. We would recommend the Township continue to coordinate this project with Bill Knetsch and other community stakeholders.

Yours truly,

A handwritten signature in blue ink that reads 'Jameson Pickard'.

Jameson Pickard
Junior Planner

c. Bill Knetsch, Enver's Morriston
Don Creed, Public Works Supervisor
Kevin Plut, MTO
Ken Teasdale, MTO
Attachments: Highway 6 Streetscape Strategy

Morrison

Highway 6 Streetscape Strategy



Landscaping

Lighting and
Banners

Gateway
Signage

July 2013

Contents

1	Background	1
2	Streetscape Strategy	1
3	Landscaping	2
4	Lighting and Banners	9
5	Gateway Signage	12
6	Next Steps	14

Figures

Figure 1	Landscaping Checklist	3
Figure 2	Planting Area 1	4
Figure 3	Planting Area 2	5
Figure 4	Planting Area 3	6
Figure 5	Planting Area 4	7
Figure 6	Planting Area 5	8
Figure 7	Banner Quote Information	10
Figure 8	Lighting and Banner Quote Information	11
Figure 9	Lighting and Banner Checklist	11
Figure 10	Signage Quote Information	13
Figure 11	Gateway Signage Checklist	14

Appendices

Appendix 1	Overall Map of Streetscape Components	15
Appendix 2	Planting Area 1 & Gateway Sign	16
Appendix 3	Planting Area 2	17
Appendix 4	Planting Area 3, Lighting & Banners	18
Appendix 5	Planting Area 4, Lighting & Banners	19
Appendix 6	Planting Area 5, Gateway Sign, Lighting & Banners	20
Appendix 7	Landscape Plan Quote	21
Appendix 8	Lighting and Banner Quote	23
Appendix 9	MTO Encroachment Permit Application Form	30



Morrison Highway 6 Streetscape Strategy

1 Background

This document is part of a series of interim solutions developed to improve the Highway 6 streetscape prior to completion of the Highway 6 by-pass. Improvements completed to date include:

- Enlarged speed limit signage installed by Ministry of Transportation (MTO)
- Identification of pedestrian crossings at main intersection with 'zebra striping' pavement markings by MTO

A Community Safety Zone designation request has also been forwarded to the Ministry of Community Safety and Correctional Services. The request was supported by Township Council, COPS Committee, the Townships Public Works Supervisor, MPP Ted Arnott, MTO, OPP, Police Services Board and County Engineer. No decision has been issued on the request at this time.

2 Streetscape Strategy

This strategy identifies three areas of streetscape improvements:

- Landscaping (trees and planting within existing paved medians at plaza)
- Lighting and Banners (upgraded luminaires and banners on existing poles)
- Gateway Signage (enhanced Morrison identification signage)

These initiatives have been championed by Bill Knetsch, a Morrison business owner. This document has been prepared by the County of Wellington Planning and Development Department. In all cases, MTO approval is required.



3 Landscaping

The landscaping component calls for the creation of five new planting areas along Highway 6 (Appendix 1). These areas were evaluated for general suitability by the Township's consulting ecologist (Greg Schiefele) and selected if there was enough space to accommodate plantings. Mr. Schiefele also recommended species which have been identified in Appendix 1 through 5.

MTO Requirements

All of the proposed planting areas would be located within the Highway 6 right-of-way and would therefore be subject to the evaluation and approval of the Ministry of Transportation (MTO). The MTO requires:

- 1) 4 copies of a Landscape Plan
- 2) An Encroachment Permit Application, once Landscape Plan is approved (Appendix 8)
- 3) Payment in the amount of \$520.00

The Landscape Plan would need to be prepared by a Landscape Architect and identify the location, type and size of plantings proposed within each area. MTO has advised of setback requirements from the traveled portion of the highway to the anticipated drip line of the trees to be planted. The compulsory setback is based on the speed limit of the road alongside which the planting areas will be placed. In this case the planting areas are within a 50km/h zone and the setback required would be a minimum 4.0 m. If the plans are approved, the Ministry will then request a single encroachment permit application be filed and the \$520.00 fee be paid. Once permits have been received installation can proceed.

Phasing of the installation of the planting locations may be an option that the Township can consider. If phased, we would recommend that the first planting areas include the outer limits of the village (planting areas # 1 and # 5), then gradually work towards the central planting area in front of the Morriston Village Plaza (Planting area # 4). This approach would improve areas with the greatest need for enhancements and would also accentuate the proposed gateway signage.

It should be noted that planting area # 3B may be impacted by grading and site improvements as part of the proposed residential subdivision (Bouck). Timing of Landscaping/planting area # 3B should be delayed or coincide with Subdivision/ Storm water management work if subdivision is approved.

Work completed to date includes:

- Identification of proposed planting areas and preparation of base mapping
- Ecological evaluation of each proposed planting area
- Request for quote for the preparation of the required landscape work plan



The following checklist identifies the necessary steps which are required to complete the landscaping improvements:

Figure 1 Landscaping Checklist

Task	Status
Identification of suitable planting areas and base map preparation	COMPLETE
Ecological evaluation of areas (constraint identification and suitable species for plantings)	COMPLETE
Preparation of a landscape plan identifying all planting locations and setbacks from anticipated drip lines	
Approval by the Township of Puslinch	
Submission to MTO: <ul style="list-style-type: none"> • 4 copies of the proposed landscape plan • Once plan is approved submission of one encroachment permit application form; and • Payment in the amount of \$520.00 	
Receive permits and MTO approval (work must commence within 6 months of permit issuance)	
Hire company to install plantings (tender process)	
Request utility locates (valid for 30 days)	
Construction of planting areas (phasing)	
Maintain areas	
If necessary renewal of encroachment permits with the Ministry prior to expiration of current permit.	

Proposed Planting Areas

PLANTING AREA # 1

This planting area is proposed south of the southern Morriston entrance sign and would continue along the slope between the sidewalk and ditch. The planting area would extend across the front of the residence at 97 Queen Street and end just north of the driveway to the residence at 107 Queen Street. Please refer to Appendix 2 for an aerial view of the proposed locations and for site constraints, planting species and planting directions.

Figure 2 **Planting Area 1**



View to north along the east side of Highway 6 from the residence at 107 Queen Street.



PLANTING AREA # 2

Planting area # 2 is proposed to be located south of the drive access for the residence at 77 Queen Street. This planting area would continue along the east side of the sidewalk on the crest of the slope, which is present in this area. The planting area would end just before the Morriston entrance sign at the south end of the village. Please refer to Appendix 3 for an aerial view of the proposed location and for site constraints, planting species and planting directions

Figure 3 Planting Area 2

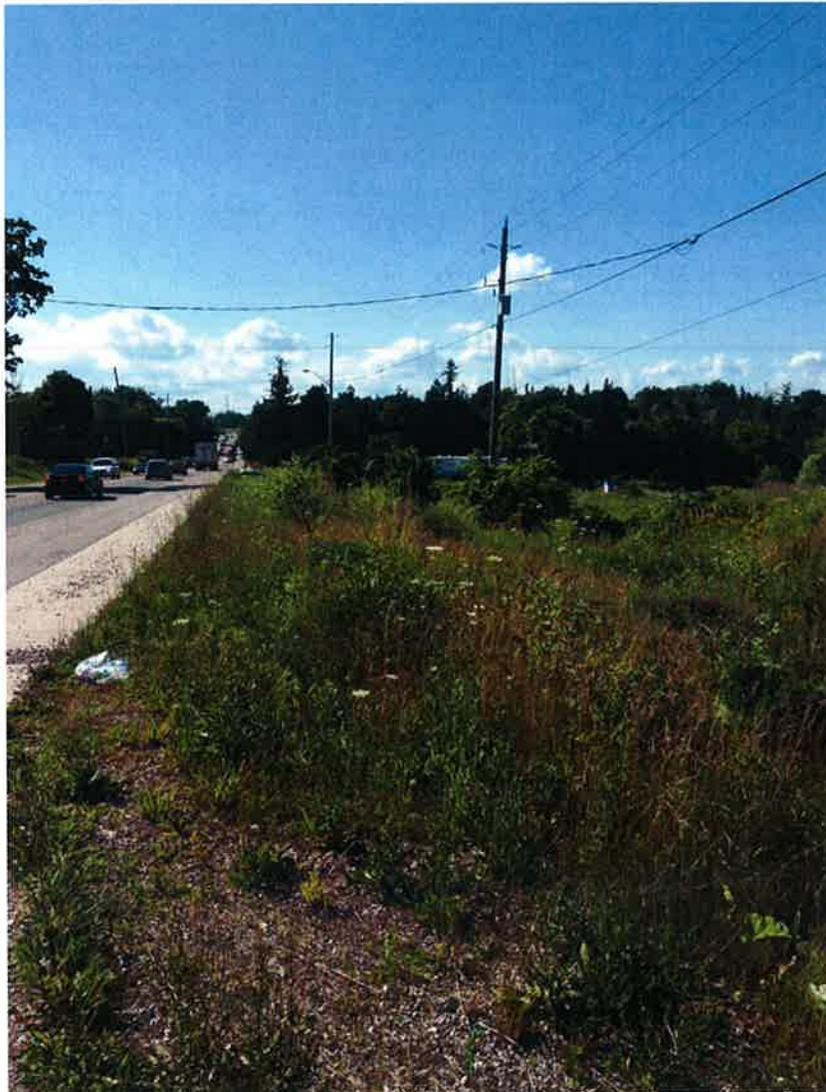

View to north along the east side of Highway 6 from southern Morriston entrance sign.

PLANTING AREA # 3

This planting area would be located immediately south of Church Street, extending south along the west side of Highway 6 for 100 m. Please refer to Appendix 4 for an aerial view of the proposed location and site constraints, planting species and planting directions.

Figure 4 Planting Area 3



View to south along the west side of Highway 6 from Church Street.



PLANTING AREA # 4

Planting area # 4 addresses the raised asphalt medians in front of the Morriston Village Plaza just north of Calfass Road. These locations, given their physical characteristics, would need to have the asphalt excavated and flowerbeds installed or low planting boxes installed on top of the paved surface. Please refer to Appendix 5 for an aerial view of the proposed location and for site constraints, planting species and planting directions.

Figure 5 Planting Area 4



View to north at proposed planting locations in medians in front of Morriston Village Plaza.



PLANTING AREA # 5

There would be two planting sites in this area:

- one lining the North American Construction storage yard located along the east side of Highway 6, south of Hwy 401 and North of Currie Drive;
- the second site is lining the west side of Highway 6 immediately across from the above mentioned planting area south of Highway 401 and north of Telfer Glen Street.

Please refer to Appendix 6 for an aerial view of the proposed locations and for site constraints, planting species and planting directions.

Figure 6 **Planting Area 5**

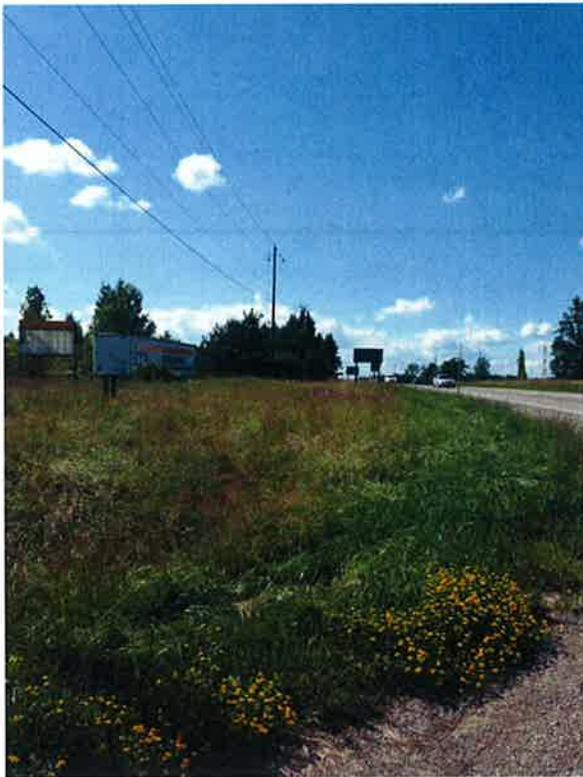

View to north from Telfer Glen Street.



View to north from Currie Drive.

4 Lighting and Banners

The lighting and banner plan proposes fourteen new street lights and banners on hydro poles throughout Morriston (Appendix 1). The new lighting fixtures and banners would create a consistent streetscape, which would identify Morriston to travelers. The new lights would introduce a heritage character and would be more visually appealing. The banners would provide the opportunity to highlight important local events or holidays.

The proposed location for these new lighting and banner installations were identified based on the availability of space on the existing hydro poles. An inventory of all hydro poles in the village was conducted during which all fixtures attached to the poles were identified (lights, traffic signals and transformers). Poles with transformers and traffic signals were eliminated from consideration due to conflicts which may arise during maintenance and repairs to those fixtures. The poles selected had no conflicting fixtures attached to them and also provided the most consistent spacing from pole to pole.

These proposed fourteen lighting and banner locations would be located within the Highway 6 right-of-way and would be subject to the evaluation and approval of the MTO.

Ministry of Transportation Requirements

The Ministry of Transportation would require:

- 1) 4 copies of the plans for the proposed lighting work
- 2) 4 copies of the plans for the proposed banner work
- 3) Once the lighting plan is approved one encroachment permit application for the proposed lighting can be submitted
- 4) Once the banner plan is approved a separate encroachment permit application for the banners can be submitted; and
- 5) Payment in the amount of \$1,040.00 covering both submissions

Two separate plans would need to be submitted to the MTO for review: a lighting plan and a banner plan. The lighting plan would provide information only pertaining to the light fixtures, and the banner plan would detail the placement of the banners. Each plan would have to include mounting height of the fixtures, fixture dimensions and location of each of the hydro poles to be used within the village. The reason for two separate plans is due to the fact that the light fixtures are viewed to be more permanent than the banner fixtures and would need to be covered by different permit conditions. If the plans are approved, the Ministry will require submission of the necessary encroachment permits for the lighting and banner installations, and payment of \$1040.00. Once permits have been received installation may proceed.



Phasing the installation of the lighting and banners may be an option that the township can consider. It would be recommended that the 8 poles, which run along the east side of Highway 6 from Church Street to just north of the intersection of Highway 6 and Badenoch Street East, and the one pole on the west side of Highway 6 north of Calfass Road be installed first. This is because these poles, given their location, would provide a consistent banner appearance and would be concentrated in the main business area. Next it would be suggested to install the lighting and banner fixtures at the two most northern proposed locations. These poles are located on either side of Highway 6, one north of Currie Drive and the other north of Telfer Glen Street. These installations would introduce banners and more lighting in the northern end of the village. Lastly the two poles located on the west side of Highway 6 south of Church Street should be installed completing the lighting and banner installations.

Work that has been done to date includes:

- Identification of suitable mounting areas preparation of base mapping
- Request for quotes for lighting fixtures and banner mounts
- Request for quotes for banners

Quote Information

Quotes were requested from 3 different companies for the creation of the banners. 1 company was requested to submit quotes for lighting fixtures and banner mounts. The details regarding their submissions are laid out in the charts below.

Figure 7 Banner Quote Information

Name	Details
Sign Art Centre Colleen Craig Guelph 519-767-2250 sales@signartcentre.com http://signartcentre.com/	Street light mounted banners 5' x 3' double sided with pockets at top and bottom would be - \$225.00 each. Fitting to the street pole would be - \$225.00 each. Final installation would be - \$120.00 each In total Each banner would be- \$570.00 Logo design if needed would be - \$210.00 Noted that the price may vary depending on how many banners would be provided
Keltech Signs Ltd Chris Hall Fergus Keltech@bellnet.ca http://www.keltechsigns.com/	Company has the ability to produce banners but would require more information regarding the dimensions and artwork that is to be placed on them. Logo design would be – \$700.00
Alpha Graphics Jeff Katerberg Fergus info@alphagraphics.ca www.alphagraphics.ca	Requested more information regarding the size and artwork to go on the banners to provide a more accurate estimate.



Figure 8 Lighting and Banner Quote Information

Name	Details
Getty and Associates Jim Campbell Kitchener/ Waterloo www.gettyassociates.ca 519.577.8172	Getty and Associates provided quotes which included prices for lighting and banner mounting assembly. The estimate which was provided was very detailed and is better suited to be read as submitted and can be found in (Appendix # 7)

The following checklist will organize the necessary steps, which are required for the completion of the plan:

Figure 9 Lighting and Banner Checklist

Task	Status
Identification of suitable installation areas	COMPLETE
Request pricing information for illumination and banners	COMPLETE
Design of banners and lighting	
Development of a detailed Lighting plan and Banner plan	
Approval by the Township of Puslinch	
Submission to MTO: <ol style="list-style-type: none"> 1) 4 copies of the plans for the proposed lighting work 2) 4 copies of the plans for the proposed banner Work 3) Once lighting plan is approved one encroachment permit application for the proposed lighting can be submitted 4) Once the banner plan is approved one encroachment permit application for the proposed banners can be submitted; and 5) Payment in the amount of \$1,040.00 covering both submissions 	
Receive Permits and MTO approval (work must commence within 6 months of permit issuance)	
Hire company to install lighting and banner fixtures (tender process)	
Notify Ministry 48 hours prior to Installation beginning	
Maintain areas	
If necessary renewal of encroachment permits with the Ministry prior to expiration of current permits.	



5 Gateway Signage

The plan for gateway signage would introduce two new entrance signs for the village. As recommended in the Puslinch Design Guidelines these signs would be more decorative in nature than the current blue and white signs in place today. With the installation of the new entrance signs it would prominently identify Morriston to those entering the community and signify that they are passing through a residential and commercial community.

The proposed locations for each of these entrance signs were determined based on several factors. Each location was evaluated based on the areas ability to accommodate the sign, the presence of other regulatory signs and the visibility of the entrance sign for travelers. The northern Morriston sign is proposed to be relocated south of its current location to an area north of Telfer Glen Street (Appendix 1). The new proposed location provides ample room for the new display sign and offers a better vantage point for travelers to see it when coming down the hill into the village. The sign located at the south end of Morriston greeting northbound traffic would not be moved but would be replaced with a new decorative sign (Appendix 2).

The proposed locations for the new entrance signs would be located within the Highway 6 right-of-way and would be subject to evaluation and approval of the MTO.

Ministry of Transportation Requirements

The Ministry of Transportation would require:

- 1) 4 copies of the plans for the proposed work
- 2) Once plan is approved one encroachment permit application can be submitted (Appendix # 8)
- 3) Payment in the amount of \$520.00

The necessary plan would need to be prepared and provided to the MTO for approval would need to include details about the location of each entrance sign as well as required setbacks. The required setback is from the traveled portion of the highway to the anticipated edge of the sign support. The compulsory setback is based on the speed limit of the road alongside which the planting areas will be placed. In this case the sign proposed to be relocated is within a 50km/h zone and the setback required would be a minimum 4.0 m. If the plans are approved, the Ministry will then request a single encroachment permit application be filed and the \$520.00 fee be paid. Once permits have been received installation can proceed. No sign permit application would be necessary upon submission to the MTO. The sign permit is only required if the proposed sign location was to be outside of the Highway 6 Right-of-way.

Work that has been done to date includes the identification of suitable sign locations, and requests for quotes regarding the manufacturing of new entrance signs.



Quote Information

Quotes were requested from 5 different Companies for the creation of the entrance signs. We used the Town of Erin and Centre Wellington Gateways signs as illustrated in the Puslinch Design Guidelines as a comparables to give a rough idea of cost. The details regarding their submissions are as follows:

Figure 10 Signage Quote Information

Name	Details
<p>Lasko 3D Signs Myron Lasko East Garafraxa Ontario 519-843-4994 myron@lasko.ca http://www.lasko3dsigns.com/</p>	<p>Lasko 3D signs was responsible for the creation of the Town of Erin Signs. Quoted a 60" x 80" sign made of western red cedar at - \$3,600 per sign. For a sign smaller than 60" x 80" an average price of \$2,500 can be expected. For a sign larger than 60" x 80" an average price of \$4,000 can be expected. Recommends staying with the 4'x 8' sheet to avoid seems.</p>
<p>Sign Art Centre Colleen Craig Guelph 519-767-2250 sales@signartcentre.com http://signartcentre.com/</p>	<p>Provided a quote to replicate the Town of Erin sign at- \$6,899 per sign Installation would be- \$600.00 per sign. Suggested to provide a more accurate estimate for the new Morriston sign, artwork would need to be determined. Logo design would be - \$ 210.00</p>
<p>Scutt Signs Jim Luesink, Sales & Design Guelph 519-821-2756 Info@scuttsigns.com http://www.scuttsigns.com/index.html</p>	<p>Requested more information regarding the proposed size and artwork of the sign. Company is capable of producing signs similar to that of Erin's and Centre Wellington's.</p>
<p>Keltech Signs Ltd Chris Hall Fergus Keltech@bellnet.ca http://www.keltechsigns.com/</p>	<p>Requested more information regarding the size and type of materials to be used in the sign. Company is able to provide logo design for approximately \$700.00 depending on detail and possible revisions.</p>
<p>Alpha Graphics Jeff Katerberg Fergus info@alphagraphics.ca www.alphagraphics.ca</p>	<p>Requested more information regarding the size and artwork to go on the sign to create an accurate quote.</p>



The following checklist will organize the necessary steps in the order that they must occur for easy tracking of the project:

Figure 11 Gateway Signage Checklist

Task	Status
Identification of suitable installation areas	COMPLETE
Requests for quotes on manufacturing	COMPLETE
Design of sign and Logo	
Creation of Detailed Sign plan	
Approval of sign and location by the Township of Puslinch	
Submission to MTO: <ul style="list-style-type: none"> • Encroachment Permit form • 4 copies of the plans for the proposed work • Payment of Fee \$23.00/m² (depending on sign size) 	
Receive permits and MTO approval (work must commence within 6 months of permit issuance)	
Have signs made	
Request utility locates (valid for 30 days)	
Notify the Ministry prior to installation beginning	
If necessary renewal of encroachment permits with the Ministry prior to expiration of current permits.	

6 Next Steps

We would recommend that the Township implement this strategy starting with the following next steps:

Landscaping

- Secure funding for Landscape Plan preparation
- Hire consultant to prepare Landscape Plan
- Finalize and approval plan
- Secure funding for landscape installation
- Seek MTO approvals

Lighting and Banners

- Secure funding for lighting and banners
- Finalize number and location of fixtures
- Request Lighting and Banner Location Plan to be prepared by County
- Seek MTO approvals

Gateway Signage

- Secure funding for gateway signage design and fabrication
- Request Sign Location Plan to be prepared by County
- Seek MTO approvals

Ongoing coordination with Bill Knetsch and other community stakeholders should continue.



APPENDIX 1 Overall Map of Streetscape Components

➤ Depicts all of the proposed streetscape components in their proposed locations



APPENDIX 2 Planting Area #1 & Gateway Sign

- Depicts planting area # 1 as well as site constraints, planting species and planting directions.
- Depicts location of proposed/ current entrance sign area at south end of Morriston.

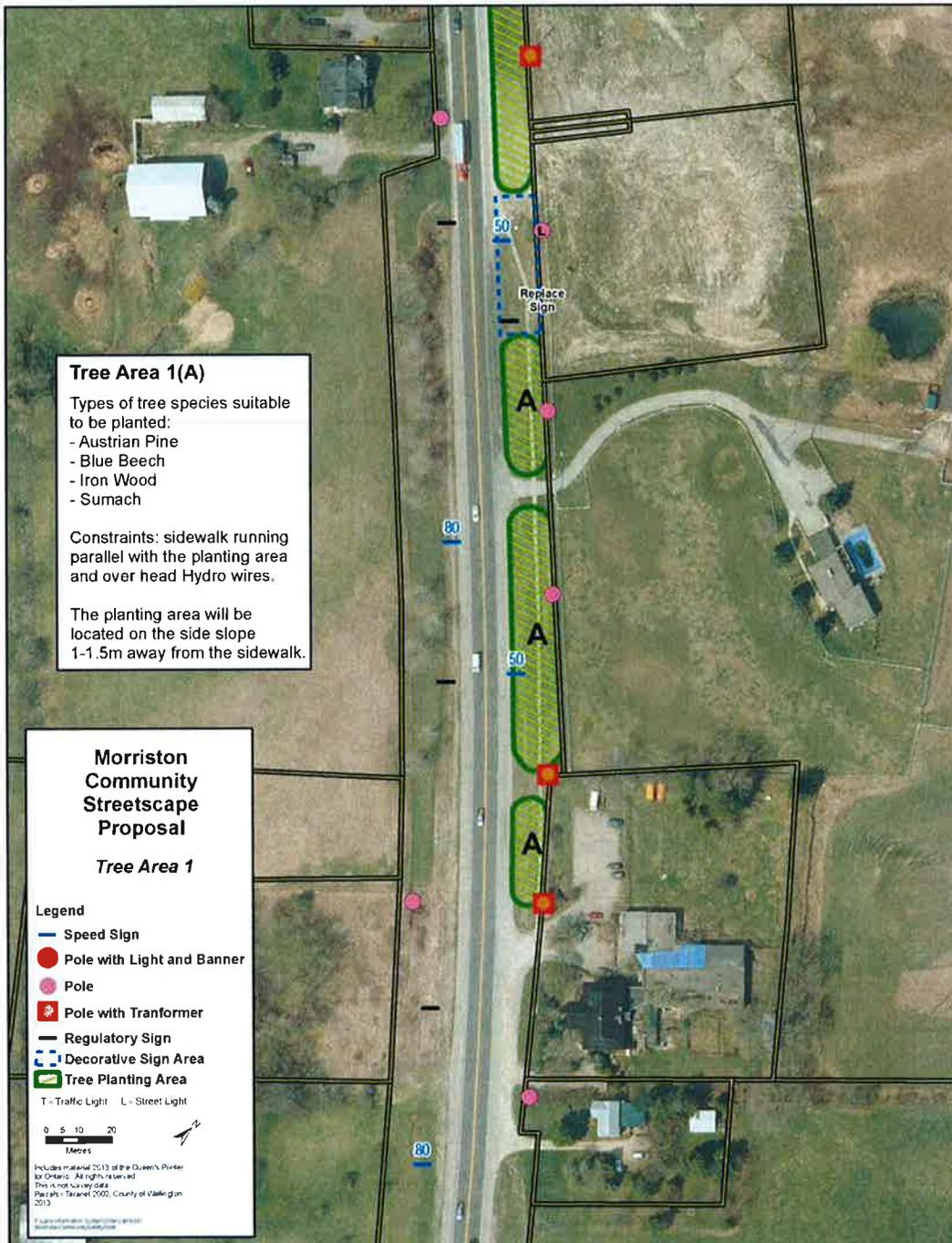

APPENDIX 3 Planting Area #2

- Depicts planting area # 2 as well as site constraints, planting species and planting directions.

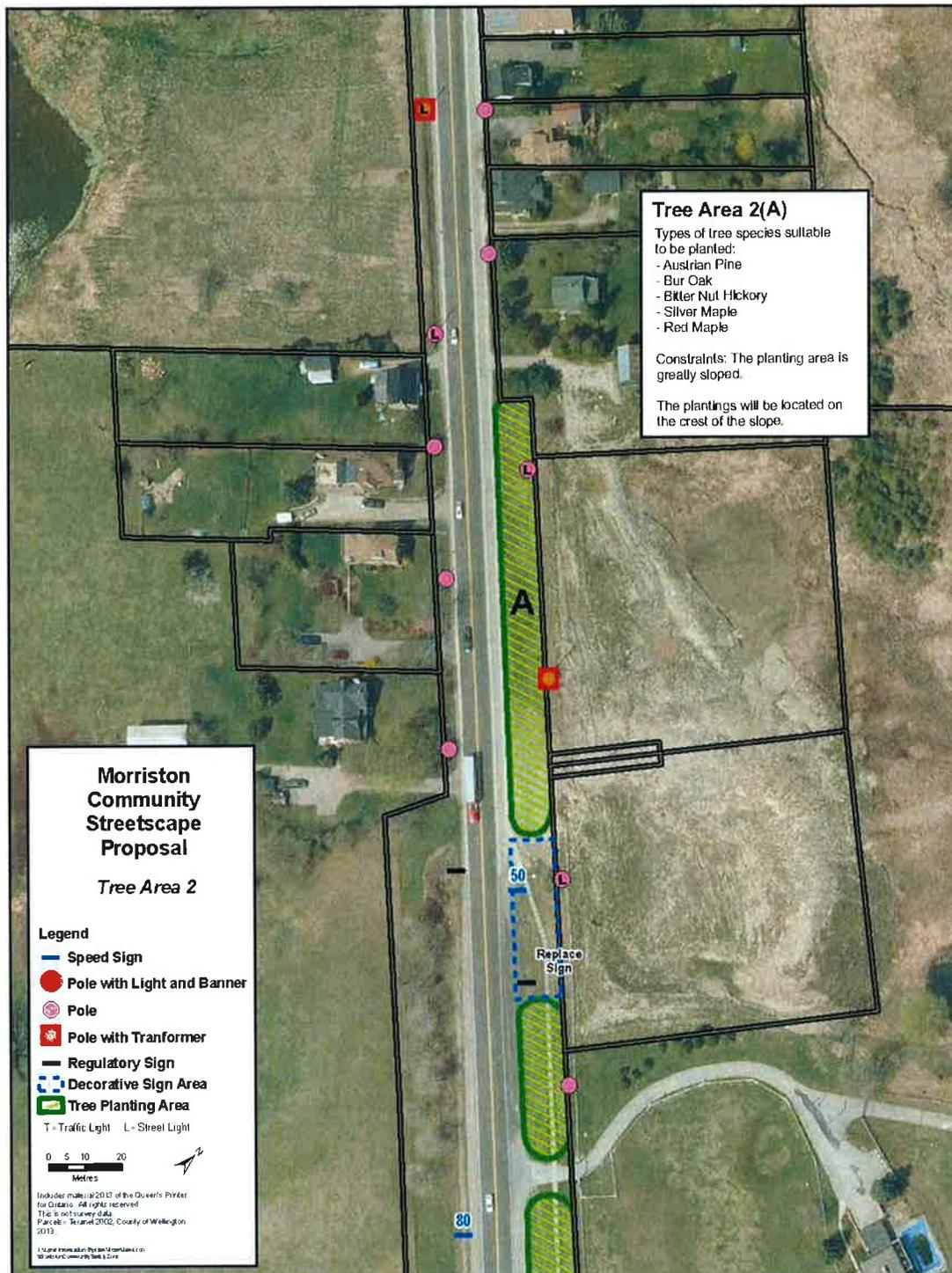

APPENDIX 4 Planting Area #3, Lighting & Banners

- Depicts planting area # 3 as well as site constraints, planting species and planting directions.
- Depicts part of the proposed lighting and banner proposed locations.



APPENDIX 5 Planting Area #4, Lighting & Banners

- Depicts planting area # 4 as well as site constraints, planting species and planting directions.
- Depicts part of the proposed lighting and banner proposed locations.

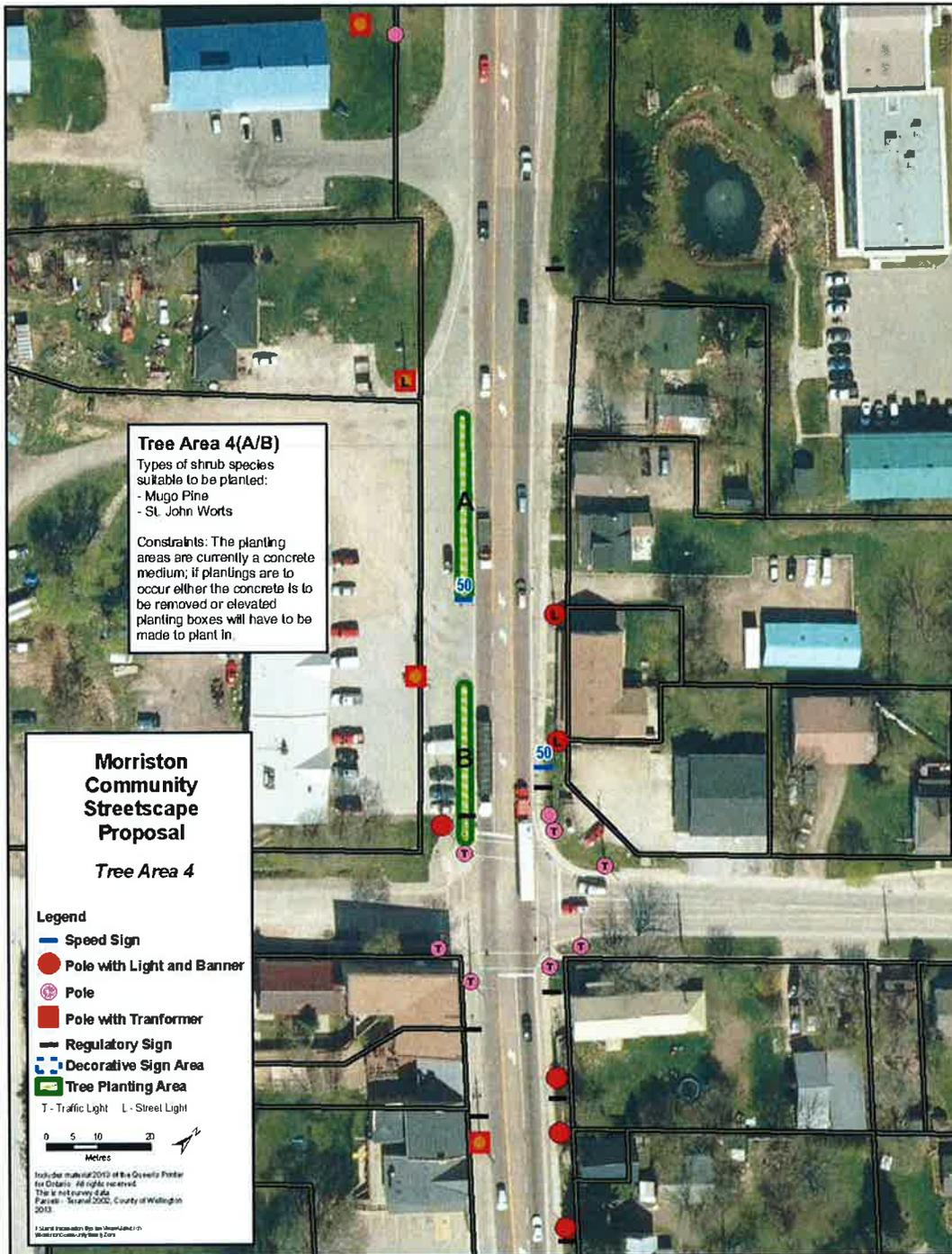

APPENDIX 6 Planting Area #5, Gateway Sign, Lighting & Banners

- Depicts planting area # 5 as well as site constraints, planting species and planting directions.
- Depicts part of the proposed lighting and banner proposed locations.
- Depicts proposed location for Entrance sign at the north end of Morriston Village.

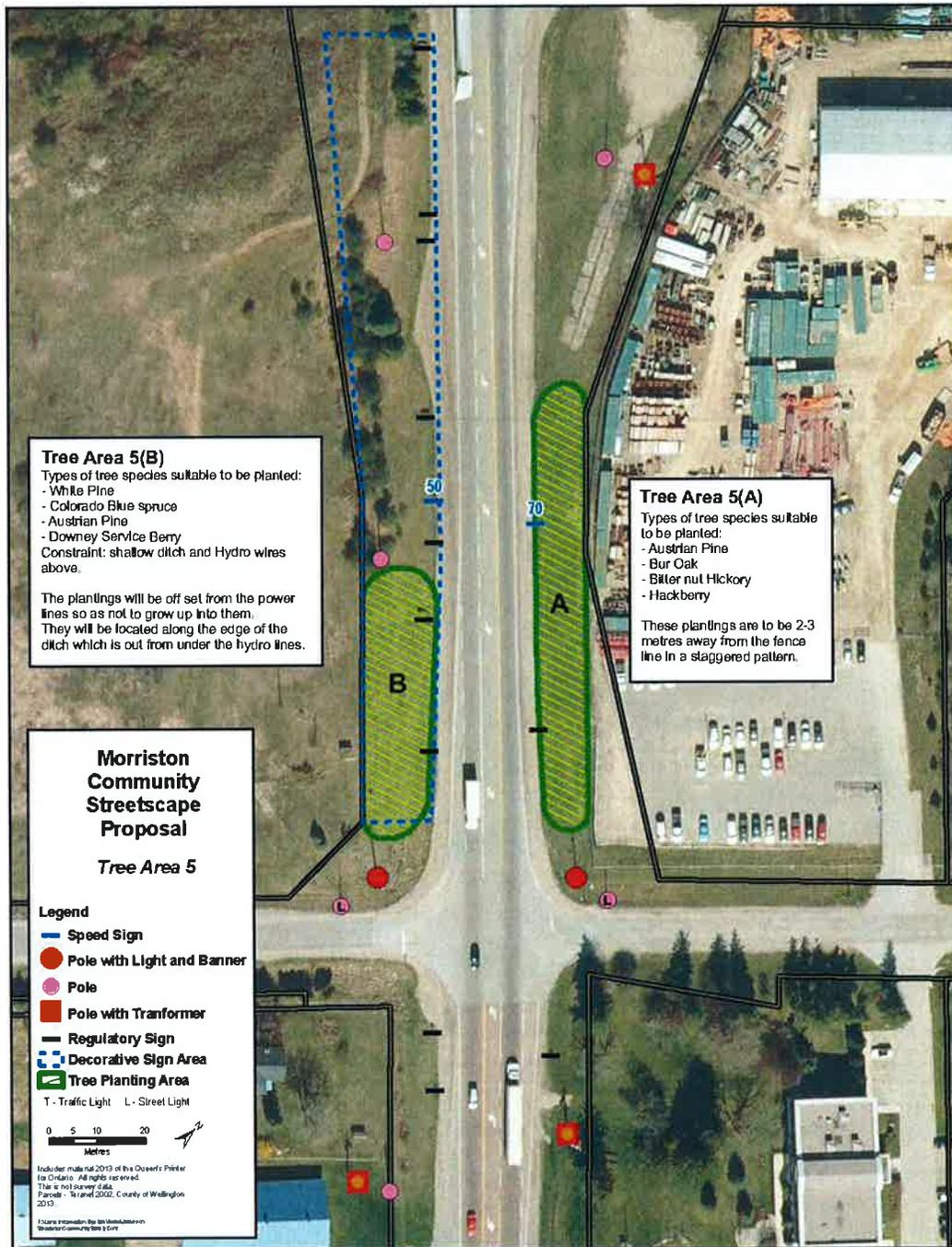

APPENDIX 7 Landscape Plan Quote

Quote information from MacKinnon and Associates about preparing a landscape plan for the proposed planting areas.



Providing Solutions in Urban, Landscape and Environmental Planning

G:\Proposals\2013\County of Wellington\Morrison rev 1.doc

File: Proposal

By E-mail: jamesonp@wellington.ca

July 19, 2013

County of Wellington
Planning and Development Department
74 Woolwich Street
Guelph, ON N1H 3T9

Attention: Mr. Jameson Pickard, Junior Planner

Dear Mr. Pickard,

Re: **Morrison Streetscape Planting
Revised Landscape Architectural Fee Estimate**

Further to our telephone discussion, we are pleased to provide the following revised estimate of fees to provide landscape architectural services for the preparation of landscape plans for certain streetscape improvements proposed in Morrison.

Based on a review of the planting areas drawings provided, our scope of work is proposed as follows:

Part A – Total Station Field Pickup of existing conditions

- Conduct total station topographic pickup of planting areas proposed for improvements. Information to be picked up includes surface and marked utilities, swales, ditches, top and bottom of banks, edge of pavement and existing trees. No allowance for private locates for underground services is made in this estimate.
- Obtain underground base information where available (gas lines, telephone etc.)
- Assemble AutoCAD base plan from survey points and available base information.

Part B - Landscape Design

- Prepare preliminary landscape plans for 5 identified planting areas. Design will accommodate recommended species as per Mr. Greg Schiefele, as well as MTO requirements. Design is anticipated to include planting design and layout, planting bed preparation recommendations, removals and rootzone improvements where necessary. We understand the County is able to provide base drawings illustrating relevant property fabric and current aerial photography. Note this estimate does not allow for the design of signage that may be considered within the "Decorative Sign Areas" noted on the sketches provided.
- Provide final OALA stamped Landscape Plans for presentation to Township Council, and for use in securing the necessary encroachment permits. No allowance is made for attendance or presentation to Council.
- Provide preliminary construction cost estimate.

Part A – Total Field Pickup Fees \$2,000 + HST and Disbursements

Part B - Total Design Fees \$3,300 + HST and Disbursements

560 Parkside Drive, Unit A21, Waterloo, Ontario, N2L 6V4 Tel. (519) 725-5140 Fax (519) 725-5144 general@mackinnonassociates.ca



Morrison | Highway 6 Streetscape Strategy
Township of Puslinch
July 2013

Mr. Jameson Pickard
July 19, 2013
Page 2 of 2

Additional services, such as rendered copies of the plans for presentation to council, tender documents and contract administration services are not included in the above estimate. In the event these, or other additional services are required, we would be please to provide an updated scope of work for your review.

We trust that the above is consistent with your request, and would ask that if acceptable, please endorse below and return to our office by fax or e-mail as authorization to proceed. Should you have any questions or concerns, please contact me directly.

Yours truly,
Mackinnon & Associates

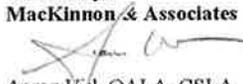
Aaron Hill, OALA, CSLA
Landscape Architect

Client Authorization and Date
Morrison Streetscape Planting
Part A – Field Pickup \$2,000 + HST and Disbursements
Part B – Design - \$3,300 + HST and Disbursements



APPENDIX 8 Lighting and Banner Quote

- Quote information from Getty and Associates about the lighting fixtures and banner mounting assembly.



Philips Lumec div. PEL
640 Curé-Boivin
Brossard (Québec) Canada J7G 2A7
Tel : 450-430-7040 / Fax: 450-430-1453
www.lumec.com

Quoter:

Jim Campbell
Getty Associates

Unknown

QUOTATION

Date: 07/03/13 09:58:31	Project: 9692- 1
Morrison	
Bidding Date: 04/28/93	

Item	Qty	Description	Unit Price
Lum	14	S41-65W49LED4K-ES-ACDR-C-LE3-120-SF41-HS-BKTX	1,705.00 \$

Series	S41	4 Sided Lantern
Lamp	65W49LED4K	Light-emitting diodes (LED) . Lumen output available through ies file.49 LED package
Lamp Type	ES	Lamp type Philips Lumileds Rebel ES.
Globe/Lens Material	ACDR	impact-resistant (DR) acrylic
Globe/Lens Finish	C	clear
Optical System	LE3	IES type III (asymmetrical)
Ballast	120	120 volts
Adaptor	SF41	Top Adaptor Slip Fitter For 4" Round Or 4" x 4" Round Pole High Tenon (L40)
Luminaire Options	HS	House side shield.
Bracket	CRA	Retro Type "A" Rectangular Tube, Anchor Plate, Decorative Scroll
Configuration	WPBB	Wood Pole Bracket With Ballast Box. Accept pole from 8"(203mm) to 12"(305mm) diameter.
Color	BKTX	black textured RAL9005TX

Bra	14	CRA-WPBB-BKTX	500.00 \$
-----	----	---------------	-----------

Series	S41	4 Sided Lantern
Lamp	65W49LED4K	Light-emitting diodes (LED) . Lumen output available through ies file.49 LED package
Lamp Type	ES	Lamp type Philips Lumileds Rebel ES.
Globe/Lens Material	ACDR	impact-resistant (DR) acrylic
Globe/Lens Finish	C	clear
Optical System	LE3	IES type III (asymmetrical)
Ballast	120	120 volts
Adaptor	SF41	Top Adaptor Slip Fitter For 4" Round Or 4" x 4" Round Pole High Tenon (L40)
Luminaire Options	HS	House side shield.
Bracket	CRA	Retro Type "A" Rectangular Tube, Anchor Plate, Decorative Scroll

(Re: VD-03)



Quoter:

Jim Campbell
Getty Associates

Unknown

QUOTATION

Date: 07/03/13 09:58:31	Project: 9692- 1
Morrison	
Bidding Date: 04/28/93	

Item	Qty	Description	Unit Price						
		<table border="1"> <tr> <td>Configuration</td> <td>WPBB</td> <td>Wood Pole Bracket With Ballast Box. Accept pole from 8"(203mm) to 12"(305mm) diameter.</td> </tr> <tr> <td>Color</td> <td>BKTX</td> <td>black textured RAL9005TX</td> </tr> </table>	Configuration	WPBB	Wood Pole Bracket With Ballast Box. Accept pole from 8"(203mm) to 12"(305mm) diameter.	Color	BKTX	black textured RAL9005TX	
Configuration	WPBB	Wood Pole Bracket With Ballast Box. Accept pole from 8"(203mm) to 12"(305mm) diameter.							
Color	BKTX	black textured RAL9005TX							
Pol	14	BACS30-BKTX	227.50 \$						
		<table border="1"> <tr> <td>Pole Options</td> <td>BA</td> <td>Banner arm, mechanically assembled to the pole. Banner Arm Type: clamp-on type, made of steel tubing, 1 1/16" (27mm) outside diameter / Configuration: Single / Banner Arm Length: 30" / Mounting: single arm(s) (1) / Tip: standard cast aluminum decorative ball</td> </tr> <tr> <td>Color</td> <td>BKTX</td> <td>black textured RAL9005TX</td> </tr> </table>	Pole Options	BA	Banner arm, mechanically assembled to the pole. Banner Arm Type: clamp-on type, made of steel tubing, 1 1/16" (27mm) outside diameter / Configuration: Single / Banner Arm Length: 30" / Mounting: single arm(s) (1) / Tip: standard cast aluminum decorative ball	Color	BKTX	black textured RAL9005TX	
Pole Options	BA	Banner arm, mechanically assembled to the pole. Banner Arm Type: clamp-on type, made of steel tubing, 1 1/16" (27mm) outside diameter / Configuration: Single / Banner Arm Length: 30" / Mounting: single arm(s) (1) / Tip: standard cast aluminum decorative ball							
Color	BKTX	black textured RAL9005TX							

Approx lead time should be 8 to 10 weeks after order is released and / or final approval of shop drawings.

Melany Kertland



All Federal, Local, State and Provincial taxes are not included.

Standard Philips Lumec div. PEL colors, if custom color add 1040\$ D/N lot, per color / per order.

Lamps are not included with exceptions to LED, induction and Cosmopolis lamps. Prices are valid for 30 days. Minimum order of 100.00\$.

Freight Allowed (for more than 6000\$).

Mode of transportation will be determined by Philips Lumec div. PEL, unless otherwise specified and requested by the purchaser, in which case the purchaser assumes any or all additional charges.

Pricing based on one shipment, one delivery date.

All sales of Philips Lumec div. PEL products shall be made pursuant to Philips Lumec div. PEL's Standard Terms and Conditions of Sale. Consult www.lumec.com to review Philips Lumec div. PEL's Standard Terms.

The bidder hereby certifies that it cannot comply with the requirements of section 165(a) of the Surface Transportation Assistance Act of 1982, as amended, but it may qualify for an exception to the requirement pursuant to section 165(b)(2) or (b)(4) of the Surface Transportation Assistance Act of 1982 and regulations in 49 CFR 661.7.



Morrison (9692)

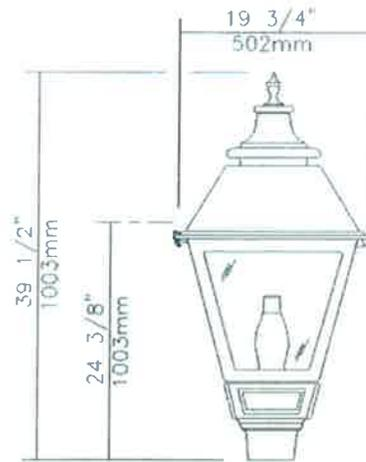

EPA: 3.25 sq ft / weight: 61 lb (27.7 kg)
Note: 3D image may not represent color or option selected.
Logos above include link, click to access.

	Qty	14	Luminaire	S41-65W49LED4K-ES-ACDR-C-LE3-120-SF41-HS-BKTX
---	-----	----	-----------	---

Description of Components:

Finial: Decorative cast 356 aluminum, mechanically assembled.

Cupola: Decorative cast 356 aluminum, mechanically mounted on hood.

Hood: In a square tapered shape, the hood is made of a one-piece die cast injection moulded A360 aluminium. Mechanically assembled to the guard.

Guard: In a square tapered shape, the guard is made of one-piece die cast injection moulded A360 aluminium.

Access-Mechanism: Two integrated hinges on the hood with a stopper and a latch shall offer a tool-free access to the inside of the luminaire. An embedded memory-retentive gasket shall ensure weatherproofing.

Light Engine: LifeLED™ composed of 5 main components: **Globe / LED lamp / Optical System / Heat Sink / Driver**
Electrical components are RoHS compliant.

Globe: (ACDR-C), Made of one-piece seamless injected-moulded clear impact-resistant (DR) acrylic. The globe is assembled on the access-mechanism.

Lamp: (Included), Lamp type Philips Lumileds Rebel ES. Composed of 49 high-performance white LEDs, 65w lamp wattage Color temperature of 4000 Kelvin nominal, 70 CRI. Operating lifespan after which the system emits 70% of its original lumen output, all of those parameters are tested for 100% of light engines. Use of a metal core board insures greater heat transfer and longer lifespan of the light engine

Optical System: (LE3), IES type III (asymmetrical) Composed of high-performance acrylic collimators, optimized with

Morrison (9692)

varying beam angles to achieve desired distribution. System is rated IP66. Performance shall be tested per LM63 and LM79 (IESNA) certifying its photometric performance. Street-side indicated. **Complete with a (HS) House side shield.**

Heat Sink: Made of cast aluminum optimising the LEDs efficiency and life. Product does not use any cooling device with moving parts (only passive cooling device)

Driver: High power factor of 90%. Electronic driver, operating range 50/60 Hz. **Auto-adjusting to a voltage between 120 and 277 volt AC rated for both application line to line or line to neutral, Class II, THD of 20% max.** Maximum ambient operating temperature from -40F(-40C) to 130F(55C) degrees. Certified in compliance to cULus requirement. Dry and damp location. Assembled on a unitized removable tray with Tyco quick disconnect plug resisting to 221F(105C) degrees.

The current supplying the LEDs will be reduced by the driver if the internal driver temperature exceeds 185F(85C), as a protection to the LEDs and the electrical components. Output is protected from short circuits, voltage overload and current overload. Automatic recovery after correction.

REMOTE BALLAST: Located inside ballast box.

Surge Protector: LED Driver 3 poles 10KV surge Protectors that protect Line-Ground, Line-Neutral, and Neutral-Ground in accordance with IEEE / ANSI C62.41.2 guidelines.

Fitter: (SF41), Cast 356 aluminum c/w 3 set screws 3/8-16. Slip-fits on a 4"(102mm) outside diameter x 4" (102mm) long tenon.



Morrison (9692)

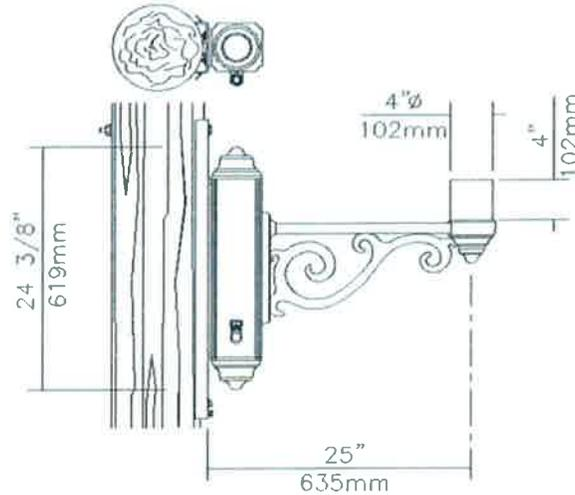
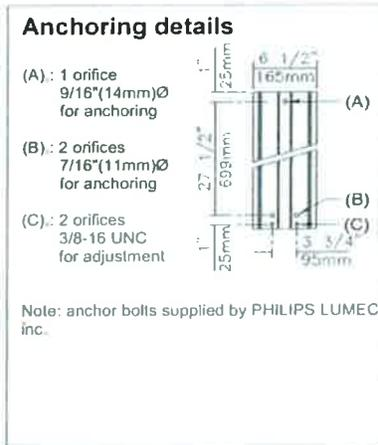

	Qty 14	Bracket CRA-WPBB-BKTX
---	---------------	------------------------------

Description of Components:

Arm: Shall be made from cast 356 aluminum complete with a 1" x 2" (25mm x 51mm) aluminum section and an anchor plate, mechanically assembled.

Wall Mount Box: (WPBB). Made of aluminum tubing 6063-T5, in a square shape complete with decorative grooves and a removable cover giving access to the wiring and ground connection. Also complete with a watertight connector 90 degrees, for 1/2" flexible conduit (TECK). (Conduit not included).

Mounting Plate: Made of aluminum 6061-T6, 1/4" (6mm) thick, complete with a ground connection and a galvanized steel bolt 1/2-13 UNC x 14" (356mm) threaded on 6 1/2" (165mm). Also complete with two galvanized wood screws 3/8" (10mm) outside diameter x 6" (152mm), two galvanized adjusting bolts 3/8-16 UNC x 2 1/2" (65mm) and nuts, mechanically fastened.
Note: Can accept a wood pole from 8" (203mm) to 12" (302mm) diameter.

Morrison (9692)

Miscellaneous

Description of Components:

Wiring: Gauge (#14) TEW/AWM 1015 or 1230 wires, 15'-0" (4.5m) minimum exceeding the mounting box.

Hardware: All exposed screws shall be stainless steel with Ceramic primer-seal basecoat to reduce seizing of the parts. All seals and sealing devices are made and/or lined with EPDM and/or silicone and/or rubber.

Finish: Color to be **black textured RAL9005TX (BKTX)** and in accordance with the AAMA 2603 standard. Application of a polyester powdercoat paint (4 mils/100 microns) with \pm 1 mils/24 microns of tolerance. The Thermosetting resins provides a discoloration resistant finish in accordance with the ASTM D 2244 standard, as well as luster retention in keeping with the ASTM D 523 standard and humidity proof in accordance with the ASTM-D2247 standard.

The surface treatment achieves a minimum of 2000 hours for salt spray resistant finish in accordance with testing performed and per ASTM-B117 standard.

LED products manufacturing standard: The electronic components sensitive to electrostatic discharge (ESD) such as light emitting diodes (LEDs) are assembled in compliance with IEC61340-5-1 and ANSI/ESD S20.20 standards so as to eliminate ESD events that could decrease the useful life of the product.

Quality Control: The manufacturer must provide a written confirmation of its ISO 9001-2008 and ISO 14001-2004 International Quality Standards Certification.

Web site information details: Click on any specific information details you need:

[Paint finish](#) / [Warranties](#) / [Installation pictures](#) / [Driver Specification](#) / [ISO 9001-2008 Certification](#) / [ISO 14001-2004 Certification](#)



Lamp technical information for S26 S40 L40U								
LED = Philips Lumileds Rebel ES, CRI = 70, CCT = 4000K (+/- 350K)								
LED rated life = 100,000 hrs ¹ - Driver rated life = 50,000 hrs								
Lamp	Typical delivered lumens ²	Typical lamp wattage (W)	Typical system wattage ³ (W)	Typical current @ 120 V (A)	Typical current @ 240 V (A)	Typical current @ 277 V (A)	IES equivalent ⁴	Luminous Efficacy Rating (lm/W)
40W49LED4K ES	3350	42	47	0.39	0.20	0.17	70 W	67
65W49LED4K ES	4200	65	72	0.60	0.30	0.26	100 W	58
90W49LED4K ES	5040	90	102	0.85	0.43	0.37	150 W	49

¹ L70 = 100,000 hrs (at ambient temperature = 25°C and forward current = 700 mA)
² May vary depending on the optical distribution used.
³ System wattage includes the lamp and the LED driver.
⁴ Compared to Square (artem) (equivalence should always be confirmed by a photometric layout)

Photometric tests are done at 25°C ambient (as requested by LM-79). If our product is used at a different ambient temperature (in g/m time average), you can multiply the lumens by the percentage below:

Ambient (°C)	-20	-10	0	5	10	15	20	25
Percentage (%)	105.8	103.3	100.0	100.8	100.0	100.0	100.0	100.0

As 4000K is our standard, photometric tests are only done with this CCT. If you want to use another CCT (6000K or 3000K), you can multiply the lumens by the percentage below:

CCT (K)	5000	4000	3000
Percentage (%)	100.0	100.0	100.0

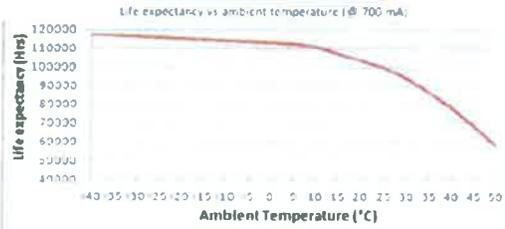

Note: Due to the nature of the LED technology, the life expectancy is subject to change in field applications and at the discretion of Philips.

APPENDIX 8

MTO Encroachment Permit Form



Ministry of
Transportation

Application for Encroachment Permit

Private/Commercial Municipal To Construct Maintain Repair Alter Remove

The following works _____

Within the limits of a highway, the works will be in place until removal or relocation is requested by M.T.O

Location

Highway No. (or Name)	On the (N S E W)	Side about (distance (km./miles))
N S E W	Nearest Town, Village or Intersection	Adjoining or adjacent to Lot No.
Concession, Plan No. or Section	Township/City	County/District/Regional Municipality

Description of Work

Crossing: Over the Highway Under the Highway The Highway at Grade Level Not Applicable

On the right-of-way for a distance of _____ as shown on the attached plan.

Distance of works from centre line _____ feet/metres From property line _____ feet/metres

Depth of works below grade of highway centre line _____ feet/metres

Length and diameter of pipe/culvert, if any _____ feet/metres

Environmental

If application is for a water line or sewer approved by or subject to the approval of the Ministry of the Environment or for a water pipe line or sewer in which that ministry is involved in any way.

Approval received Yes No Attach copy of approval Not Applicable

Indicate which, if any, of the following will be affected:

NIL Highway Drainage Trees, Shrubs, Plantings Guide Rail Signs Wetland

Four (4) copies of detailed plan and profile, drawn to scale and the specifications of the encroachment showing type, design and material must accompany each application

For Private/Commercial & Municipal Applicants

In consideration of any permit issued in respect to this application, the applicant and all successors and assigns hereby agree to observe, keep, and perform and be subject to the regulations and conditions of the said permit and to indemnify and save harmless, Her Majesty the Queen, represented by the Minister of Transportation from and against all loss, cost, charges, damages, expenses, claims and demands whatsoever to which Her Majesty may be put or which She may suffer or sustain or for which She may be liable by reason of anything done or omitted to be done in the construction, maintenance, alteration or operation of works authorized.

Permittees shall give notification to the ministry 96 hours before commencement of the authorized works

For Private & Commercial Applicants

It is understood that all works will be constructed, altered, maintained or operated at the expense of the applicant; that work must not be begun before a permit has been issued by the ministry, and that the issue of a permit by the ministry does not relieve the applicant of the responsibility of complying with relevant municipal by-laws.

A fee in the amount of \$ _____ is enclosed. Please make cheques or money orders payable to the Minister of Finance

Name of applicant/firm or municipality		Telephone No.	
Address	City/Town/Village	Province	Postal Code
Signature		Date (yyyy/mm/dd)	

Information in this form is collected under the authority of the *Public Transportation and Highway Improvement Act*, R.S.O. 1990, c. 50, s. 31, 34, 38, and is used to control and record the issuance of this permit. Direct inquiries to Senior Policy Adviser, Operations Office, 2nd Floor, 301 St. Paul Street, St. Catharines, Ontario L2R 7R4, Telephone: 905 704-2916

PH-A-5-E (03/2007)

Version française disponible

© Queen's Printer for Ontario, 2007



Morrison | Highway 6 Streetscape Strategy

Township of Puslinch

July 2013